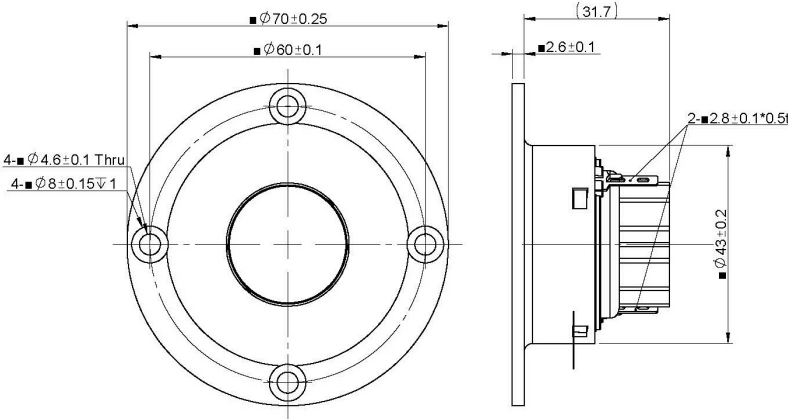

- Neodymium Motor
- Ferrofluid Filled Motor
- Fabric Diaphragm
- High Sensitivity
- Enhanced Voice Coil Cooling

**SPECIFICATIONS**

Transducer Size	1	in
Impedance	4	$\Omega$
Frequency Range <sup>1</sup>	1000 - 13000	Hz
Sensitivity <sup>2</sup> (2.83V   1W @ 1m)	99.3   96.3	dB
Power Rating (IEC 268-5)	100	W
Voice Coil Size	25.4	mm
Air Gap   Winding Height	H <sub>ag</sub>   H <sub>vc</sub>	2   2
Net Weight	0.08	kg

**PARAMETERS <sup>3</sup>**

Eff. Piston Area	S <sub>d</sub>	6.61	cm <sup>2</sup>
DC Resistance	R <sub>e</sub>	2.8	$\Omega$
Minimum Impedance	Z <sub>min</sub>	3.2	$\Omega$
Inductance	L <sub>e</sub>	0.023	mH
Resonance Frequency <sup>4</sup>	F <sub>s</sub>	1600	Hz
Mechanical Q Factor	Q <sub>ms</sub>	4.91	-
Electrical Q Factor	Q <sub>es</sub>	1.58	-
Total Q Factor	Q <sub>ts</sub>	1.2	-
Moving Mass	M <sub>ms</sub>	0.258	g
Compliance	C <sub>ms</sub>	36	$\mu\text{m}/\text{N}$
Equivalent Volume	V <sub>as</sub>	0.002	L
Motor Force Factor	Bl	2.19	Tm
Motor Efficiency	$\beta$	1.69	(Bl) <sup>2</sup> / R <sub>e</sub>
Linear Excursion <sup>5</sup>	X <sub>max</sub>	0.667	mm

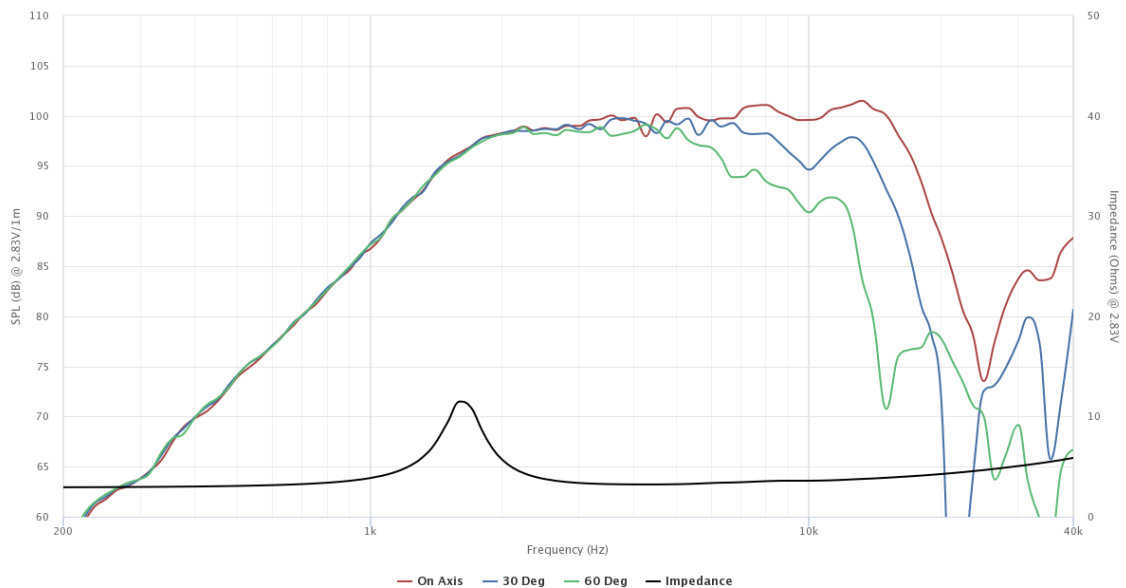

Details on this spec sheet are for reference only and should not be used for setting production limits. Specifications and product cosmetics are subject to change without notice. Peerless is a registered trademark of Tympany Enterprises. All measurements conducted in test lab at 25°C  $\pm$  10°C, 50%RH  $\pm$  10%. <sup>1</sup> Specified by Engineering as linear working range of transducer. <sup>2</sup> Measured at 2.83V at 1m and normalized to 1W with respect to nominal impedance. <sup>3</sup> Measured in Free Air without preconditioning, therefore subject to some deviation. <sup>4</sup> Impedance and F<sub>s</sub> value measured under different conditions. <sup>5</sup> Equal/Overhung:  $(H_{vc} - H_{ag})/2 + H_{ag}/3$ . Underhung:  $(H_{ag} - H_{vc})/2 + H_{vc}/3$ . <sup>6</sup> Mechanically limited excursion (e.g. bottoming, spider crash).